

Illustration Auswurf-träger fangkorb

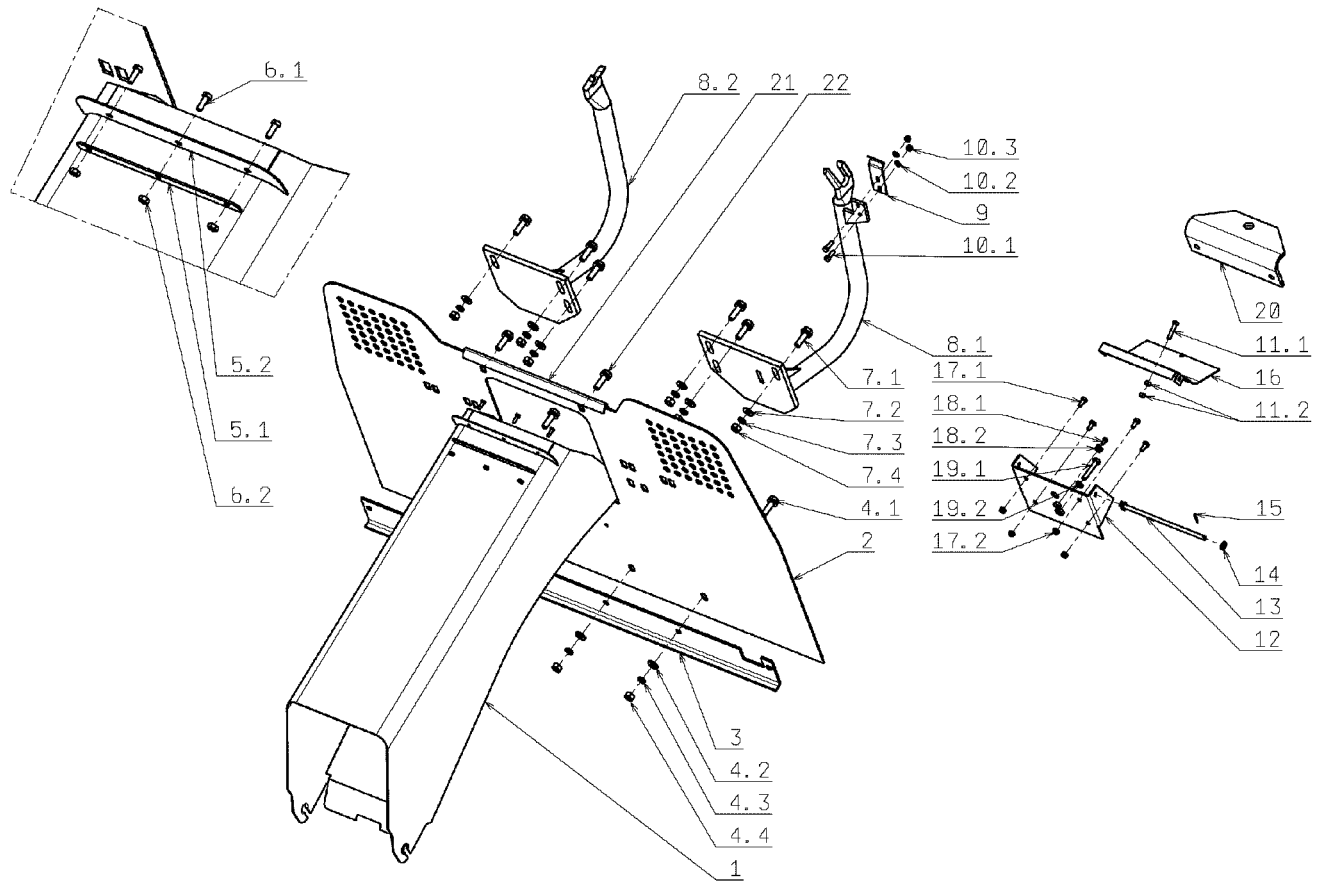

Illustration Auswurf-träger fangkorb

Bild Nr.	St.- Zahl	Teile Nr.	Beschreibung
1	1	SG532974472263	Auswurfschacht
2	1	SG532974422173	Deflector
3	1	SG532113403233	Halter
4.1	4	SG309578011	Schraube
4.2	2	SG311210503	Scheibe
4.3	6	SG311214502	Scheibe
4.4	6	SG311150503	Mutter
5.1	1	SG532115308573	Scheibe
5.2	1	SG532113322813	Halter
6.1	3	SG309231502	Schraube
6.2	3	SG311120505	Mutter
7.1	6	SG309578012	Schraube
7.2	6	SG311210503	Scheibe
7.3	1	SG311214502	Scheibe
7.4	7	SG311150503	Mutter
8.1	1	SG532974432223	Halter
8.2	1	SG532974432233	Halter
9	1	SG532097452243	Feder
10.1	2	SG309203539	Schraube
10.2	2	SG311210501	Scheibe
10.3	2	SG311129515	Mutter
11.1	1	SG309019520	Schraube
11.2	2	SG311120530	Mutter
12	1	SG532913462413	Halter
13	1	SG532150531	Stange
14	2	SG311210502	Scheibe
15	2	SG311338501	Stift
16	1	SG532085352033	Schlüssel
17.1	4	SG309203539	Schraube
17.2	4	SG311129515	Mutter
18.1	1	SG309231505	Schraube
18.2	1	SG315231195	Feder
19.1	1	SG309203559	Schraube
19.2	1	SG311120513	Mutter
20	1	SG532150296	Aufhängung
21	1	SG532096362013	Dichtung
22	2	SG309503005	Schraube

Illustration Eletrischeile

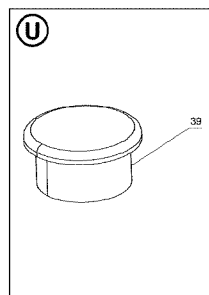
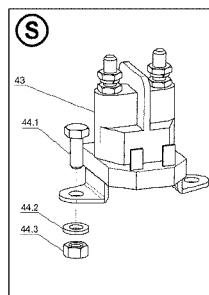
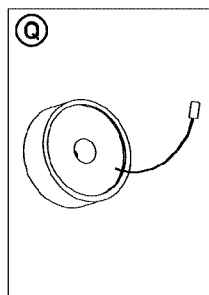
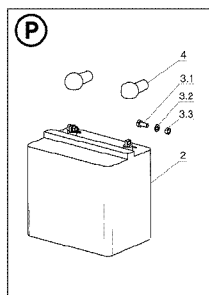
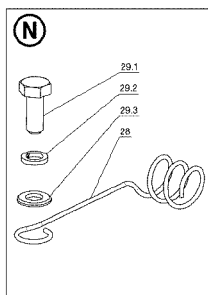
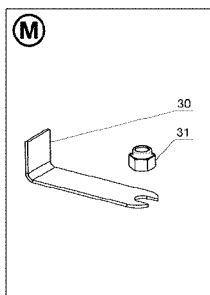
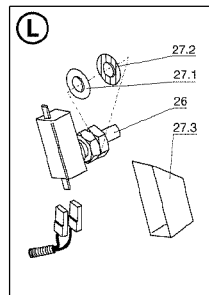
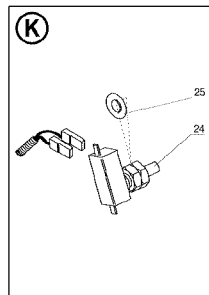
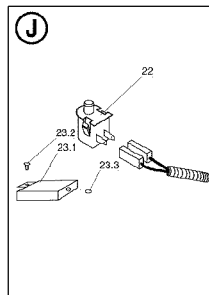
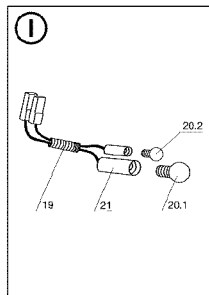
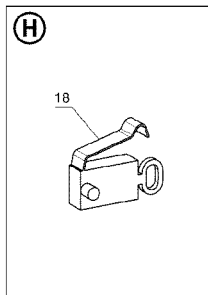
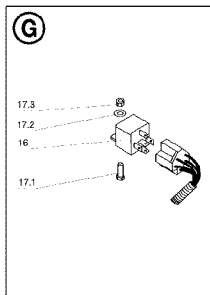
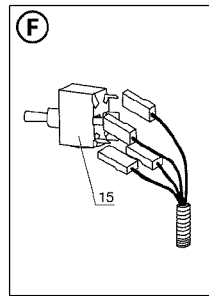
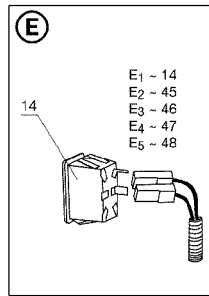
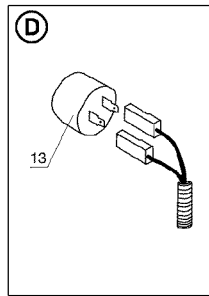
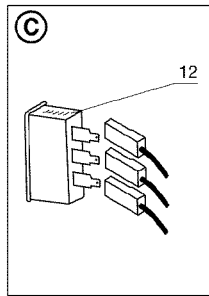
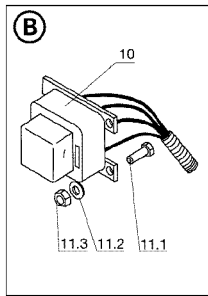
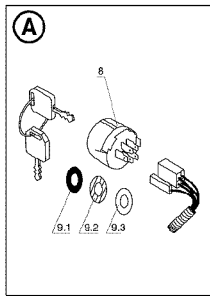
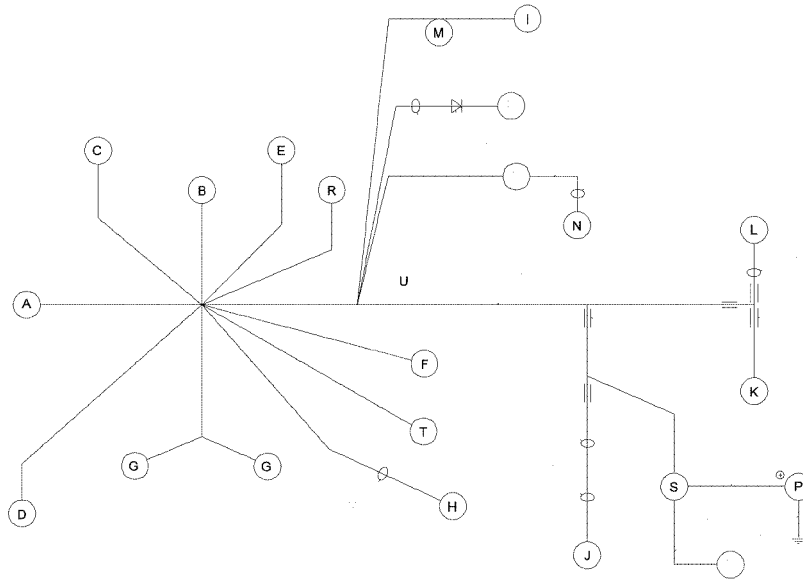

Illustration Elektrische Teile

Bild Nr.	St.- Zahl	Teile Nr.	Beschreibung
2	1	SG346211006	Batterie
3.1	2	SG309503548	Schraube
3.2	2	SG311210502	Scheibe
3.3	2	SG311129513	Mutter
4	2	SG273125006	Deckel
8	1	SG443861005	Sperre
9.1	1	SG532092207513	Scheibe
9.2	1	SG311219502	Scheibe
9.3	1	SG548712011	Ring
11.1	2	SG309203548	Schraube
11.2	2	SG311210501	Scheibe
11.3	2	SG311129515	Mutter
12	1	SG443433002	Schalter
13	1	SG443312021	Sperre
14	1	SG345329013	Schalter
15	1	SG000532039	Schalter
16	2	SG443811004	Relais
17.1	2	SG309203548	Schraube
17.2	2	SG311210501	Scheibe
17.3	2	SG311129515	Mutter
18	1	SG345329014	Schalter
19	1	SG341271036	Leiter
20.1	2	SG347224006	Glühlampe
21	2	SG443953001	Sockel
22	1	SG000532079	Schalter
23.1	1	SG532085427153	Sitz
23.2	1	SG311691001	Niete
23.3	1	SG273121035	Buchse
24	1	SG358113026	Schalter
25	2	SG311210505	Scheibe
26	1	SG358113026	Schalter
27.1	1	SG311210505	Scheibe
27.2	1	SG311219498	Scheibe
27.3	1	SG532085427173	Deckel
28	1	SG532150125	Halter
29.1	1	SG309503518	Schraube
29.2	1	SG311210503	Scheibe
29.3	1	SG311214502	Scheibe
30	1	SG532113402583	Halter
31	2	SG311129515	Mutter
39	1	SG532150055	Deckel
43	1	SG000532033	Solenoid
44.1	2	SG309503508	Schraube
44.2	2	SG311210502	Scheibe
44.3	2	SG311129513	Mutter
45	1	SG345329017	Schalter

Illustration Eletrischeile

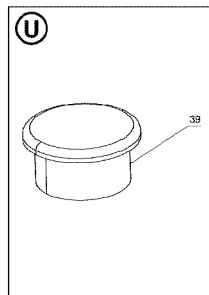
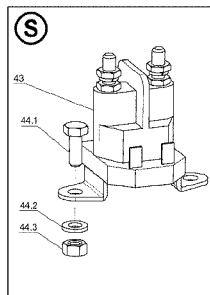
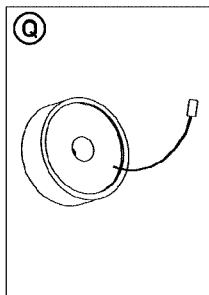
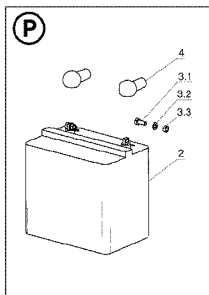
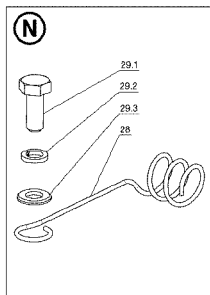
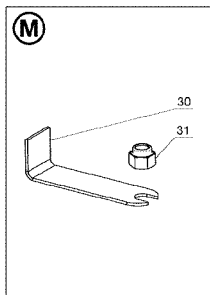
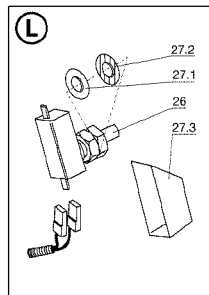
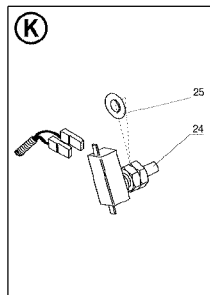
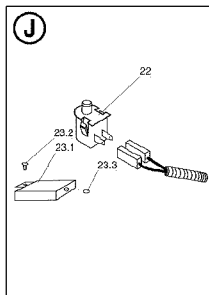
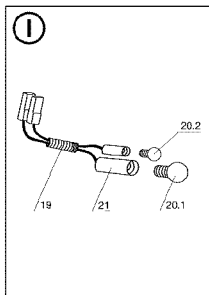
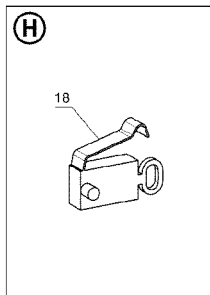
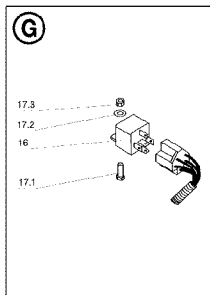
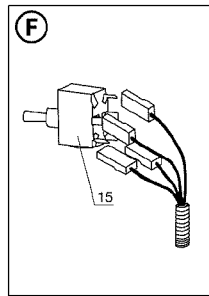
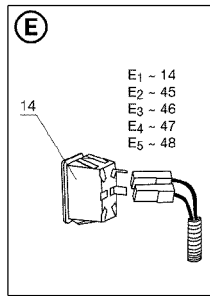
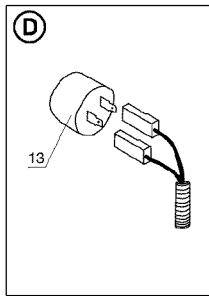
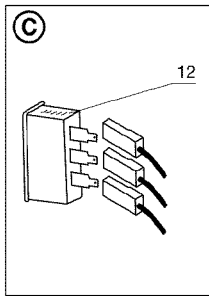
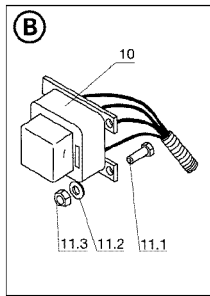
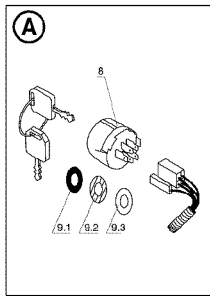
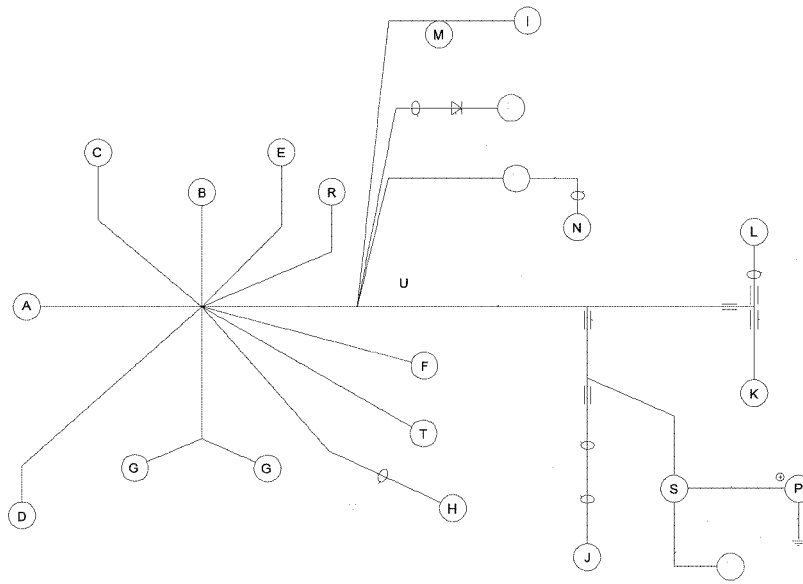

Illustration Elektrischeile

Bild Nr.	St.- Zahl	Teile Nr.	Beschreibung
46	1	SG345329015	Auftrenner

Illustration Getriebe

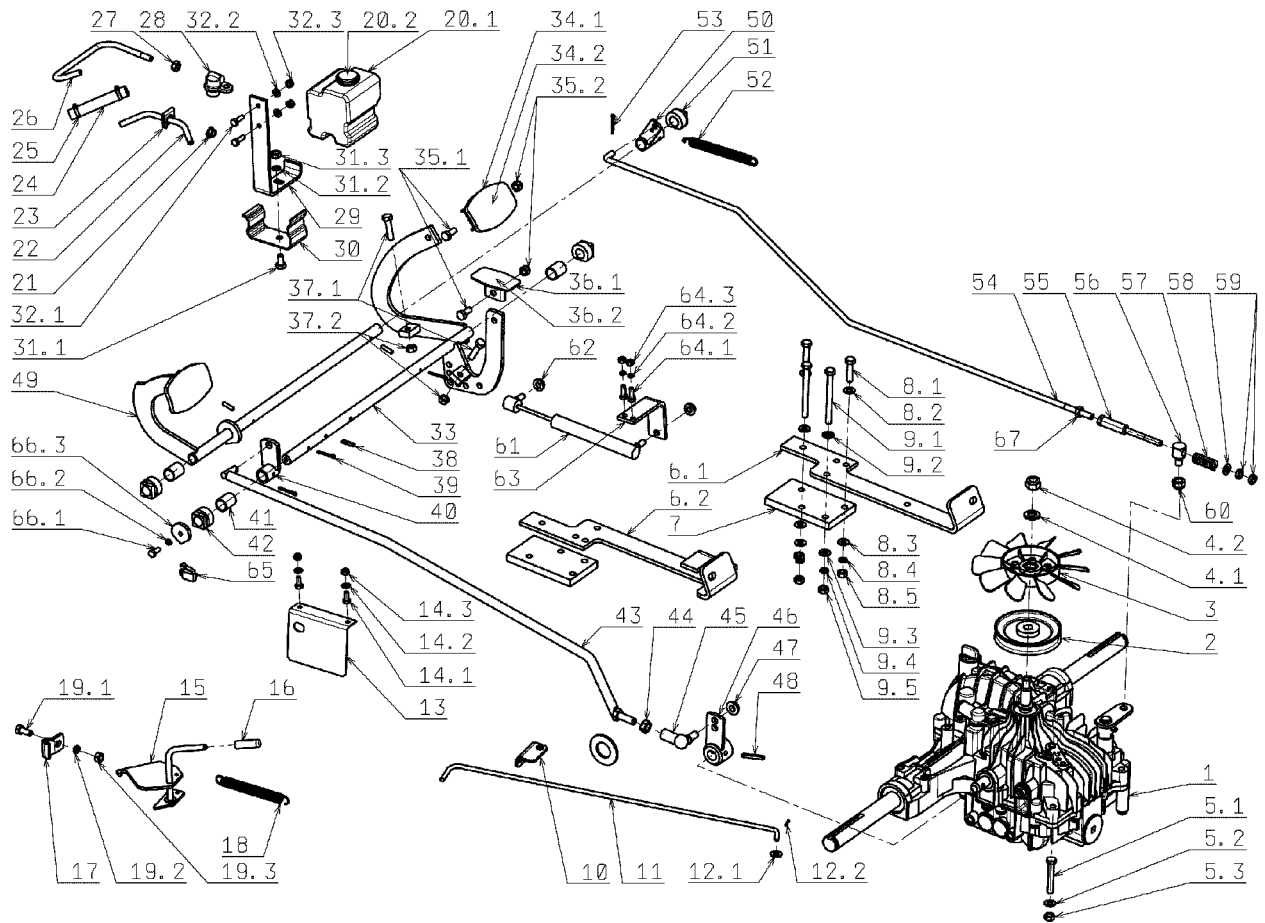

Illustration Getriebe

Bild Nr.	St.- Zahl	Teile Nr.	Beschreibung
1	1	SG532991054	Antrieb
2	1	SG532150414	Lufferrad
3	1	SG532150415	Scheibe
4.1	1	SG311212507	Scheibe
4.2	1	SG311129502	Mutter
5.1	1	SG309503556	Schraube
5.2	1	SG311210503	Scheibe
5.3	3	SG311129501	Mutter
6.1	1	SG532113403863	Halter
6.2	1	SG532913368523	Halter
7	2	SG532013312113	Scheibe
8.1	4	SG309503543	Schraube
8.2	4	SG311210503	Scheibe
8.3	4	SG311210503	Scheibe
8.4	4	SG311214502	Scheibe
8.5	4	SG311150503	Mutter
9.1	4	SG309501567	Schraube
9.2	4	SG311210503	Scheibe
9.3	4	SG311210503	Scheibe
9.4	4	SG311214502	Scheibe
9.5	4	SG311150503	Mutter
10	1	SG532113403993	Halter
11	1	SG532080412963	Spannstange
12.1	1	SG311210502	Scheibe
12.2	1	SG311338513	Stift
13	1	SG532113308233	Deckel
14.1	2	SG309203540	Schraube
14.2	1	SG311210502	Scheibe
14.3	2	SG311129513	Mutter
15	1	SG532980712323	Hebel
16	1	SG532150209	Deckel
17	1	SG532080412363	Halter
18	1	SG315231160	Feder
19.1	1	SG309503518	Schraube
19.2	1	SG311214502	Scheibe
19.3	1	SG311150503	Mutter
20.1	1	SG532150372	Hälter
20.2	1	SG532150374	Ventil
21	1	SG532150373	Dichtung
22	1	SG532082412143	Rohrleitung
23	1	SG532092402543	Ring
24	1	SG532199202423	Schlauch
25	2	SG548241016	Rohr
26	1	SG532082402153	Rohrleitung
27	1	SG311120538	Mutter
28	1	SG532082472073	Flansch

Illustration Getriebe

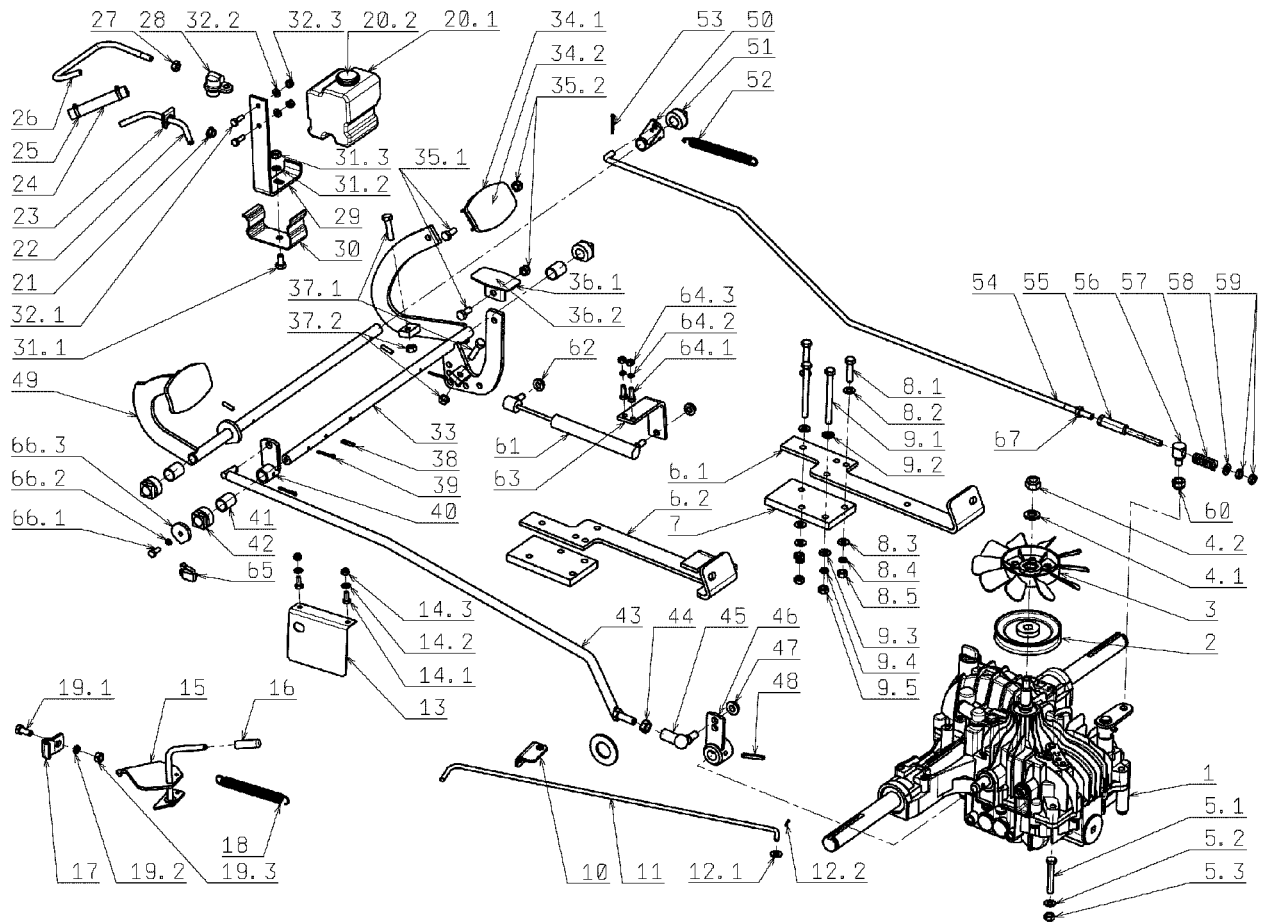

Illustration Getriebe

Bild Nr.	St.- Zahl	Teile Nr.	Beschreibung
29	1	SG532113414193	Halter
30	1	SG532150375	Halter
31.1	1	SG309203503	Schraube
31.2	1	SG311214502	Scheibe
31.3	1	SG311150503	Mutter
32.1	2	SG309503548	Schraube
32.2	2	SG311210502	Scheibe
32.3	2	SG311129513	Mutter
33	1	SG532980442213	Hebel
34.1	2	SG532980512573	Fusshebel
34.2	2	SG273151001	Pedalbelag
35.1	2	SG309503518	Schraube
35.2	2	SG311129501	Mutter
36.1	1	SG532980512583	Fusshebel
36.2	1	SG273151011	Pedalbelag
37.1	2	SG309503543	Schraube
37.2	2	SG311120520	Mutter
38	1	SG315238037	Stift
39	2	SG311338517	Stift
40	1	SG532980364823	Arm
41	2	SG532150541	Distanzstück
42	2	SG722643023	Lager
43	1	SG532980422123	Hebel
44	1	SG311150506	Mutter
45	1	SG442073021	Dichtung
46	1	SG532929462053	Hebel-komplet
47	1	SG311129516	Mutter
48	1	SG315238049	Stift
49	1	SG532980442263	Bremsepedal
50	1	SG532980365183	Kupplungsblock
51	1	SG722643023	Lager
52	1	SG315231161	Feder
53	1	SG311338501	Stift
54	1	SG532080422503	Anschluss
55	1	SG532980112083	Schraube
56	1	SG532150507	Schraube
57	1	SG315231171	Feder
58	1	SG311212517	Scheibe
59	1	SG311150503	Mutter
60	1	SG311129502	Mutter
61	1	SG532150169	Stosshaempfer
62	1	SG311150503	Mutter
63	1	SG532014408573	Halter
64.1	2	SG309203540	Schraube
64.2	2	SG311210502	Scheibe
64.3	2	SG311129513	Mutter

Illustration Getriebe

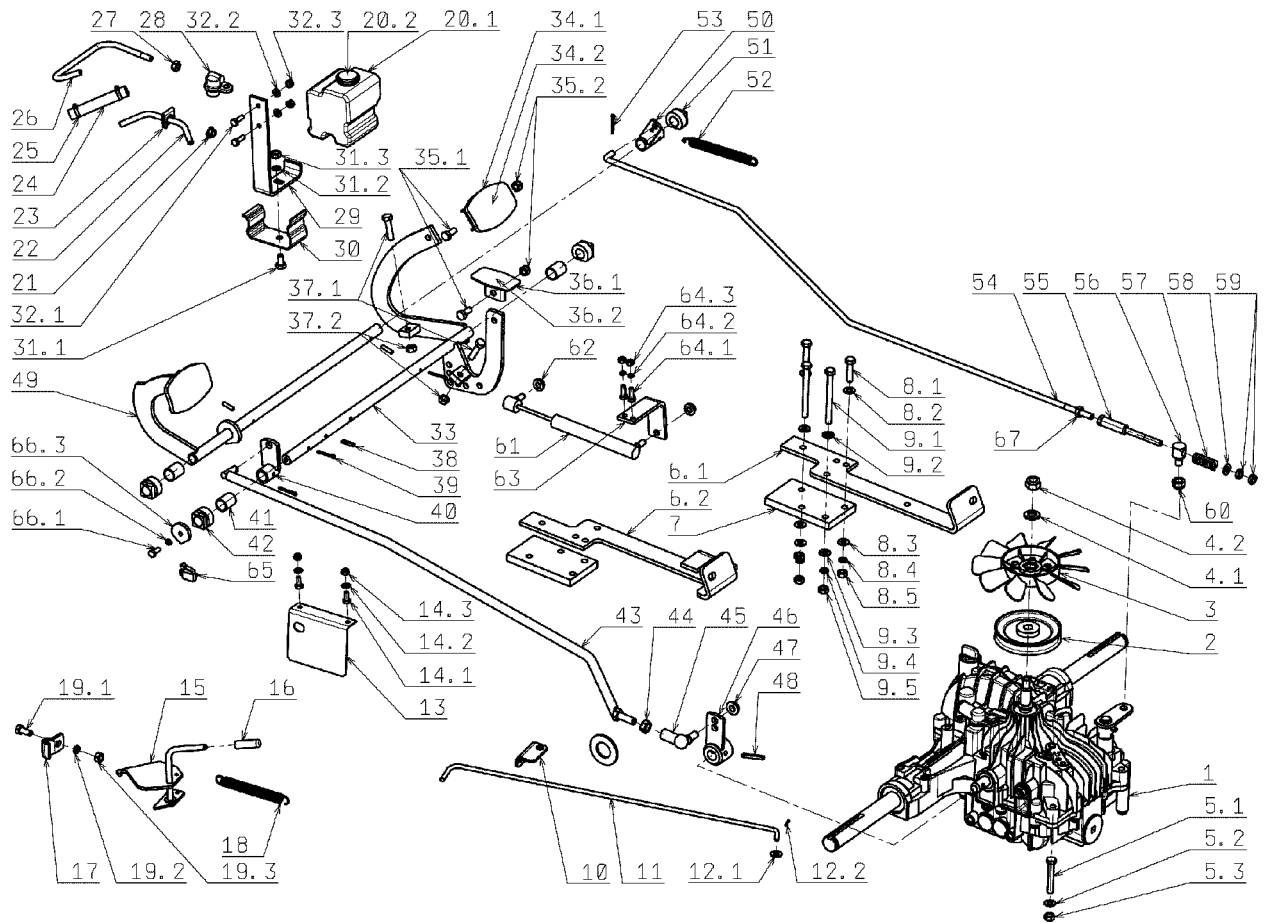

Illustration Getriebe

Bild Nr.	St.- Zahl	Teile Nr.	Beschreibung
65	1	SG345329014	Schalter
66.1	1	SG309578507	Schraube
66.2	1	SG311214501	Scheibe
66.3	1	SG532092208353	Scheibe

Illustration Grasfangkorb

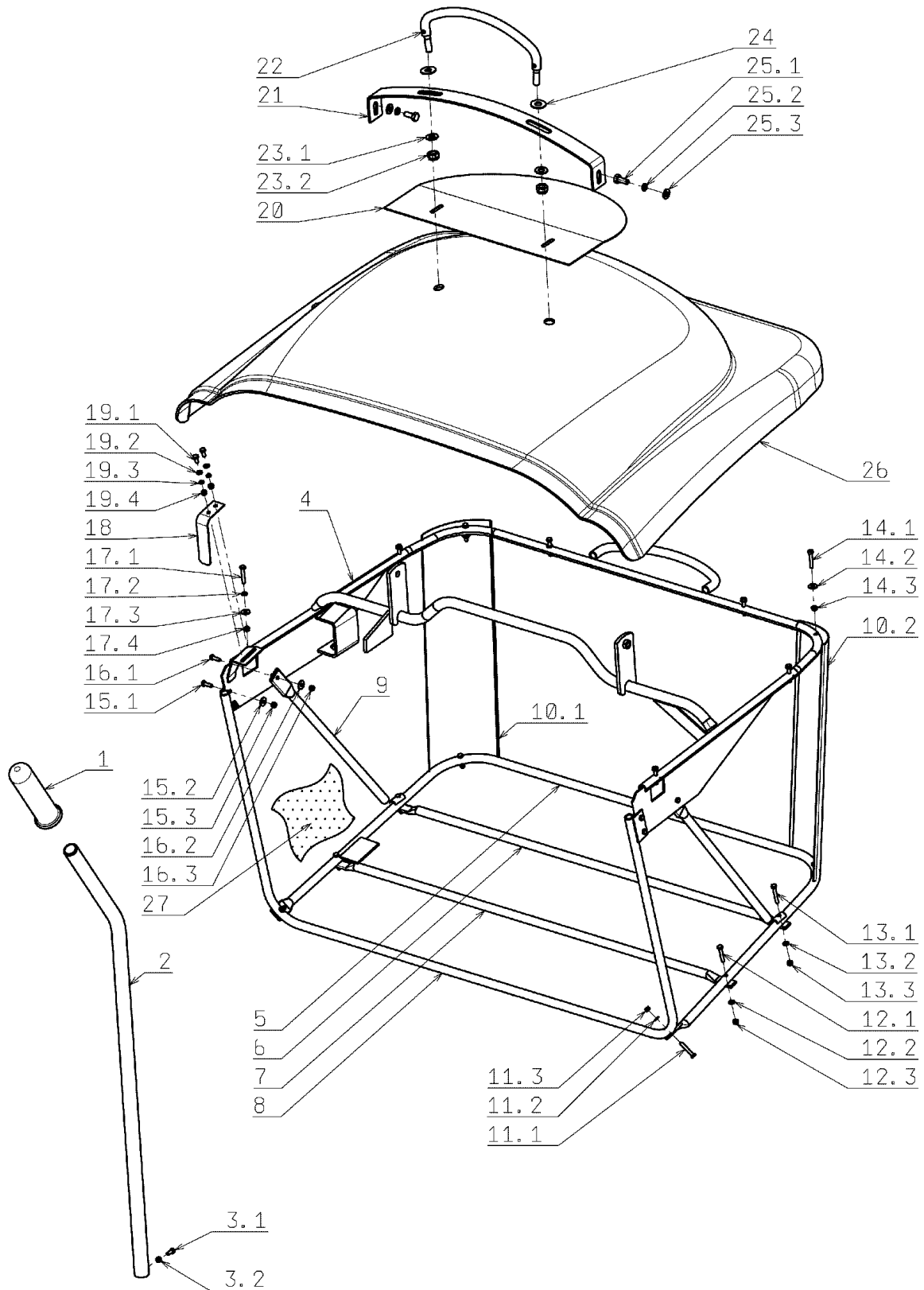

Illustration Grasfangkorb

Bild Nr.	St.- Zahl	Teile Nr.	Beschreibung
1	1	SG532150007	Handgriff
2	1	SG532150701	Hebel
3.1	1	SG309203548	Schraube
3.2	1	SG311129515	Mutter
4	1	SG532150714	Oberer rahmen
5	1	SG532150704	Rohr unten
6	1	SG532150706	Rohr
7	1	SG532150705	Rohr
8	1	SG532150702	Rohr vorn
9	2	SG532150703	Rohr
10.1	1	SG532150699	Rohr
10.2	1	SG532150698	Rohr
11.1	2	SG309203555	Schraube
11.2	2	SG311210501	Scheibe
11.3	2	SG311129515	Mutter
12.1	2	SG309203555	Schraube
12.2	2	SG311210501	Scheibe
12.3	2	SG311129515	Mutter
13.1	2	SG309203556	Schraube
13.2	2	SG311210501	Scheibe
13.3	2	SG311129515	Mutter
14.1	4	SG309203557	Schraube
14.2	4	SG311210501	Scheibe
14.3	4	SG311129515	Mutter
15.1	4	SG309019514	Schraube
15.2	4	SG311212514	Scheibe
15.3	4	SG311129515	Mutter
16.1	2	SG309203539	Schraube
16.2	2	SG311210501	Scheibe
16.3	2	SG311129515	Mutter
17.1	6	SG309203555	Schraube
17.2	6	SG311212514	Scheibe
17.3	6	SG311210501	Scheibe
17.4	6	SG311129515	Mutter
18	1	SG532150708	Plate
19.1	2	SG309203548	Schraube
19.2	2	SG311210501	Scheibe
19.3	2	SG311214507	Scheibe
19.4	2	SG311129515	Mutter
20	1	SG532150707	Deckel
21	1	SG532150710	Verstaerkung
22	1	SG532150709	Handgriff
23.1	2	SG311210504	Scheibe
23.2	2	SG311129502	Mutter
24	2	SG311212040	Scheibe
25.1	2	SG309203504	Schraube

Illustration Grasfangkorb

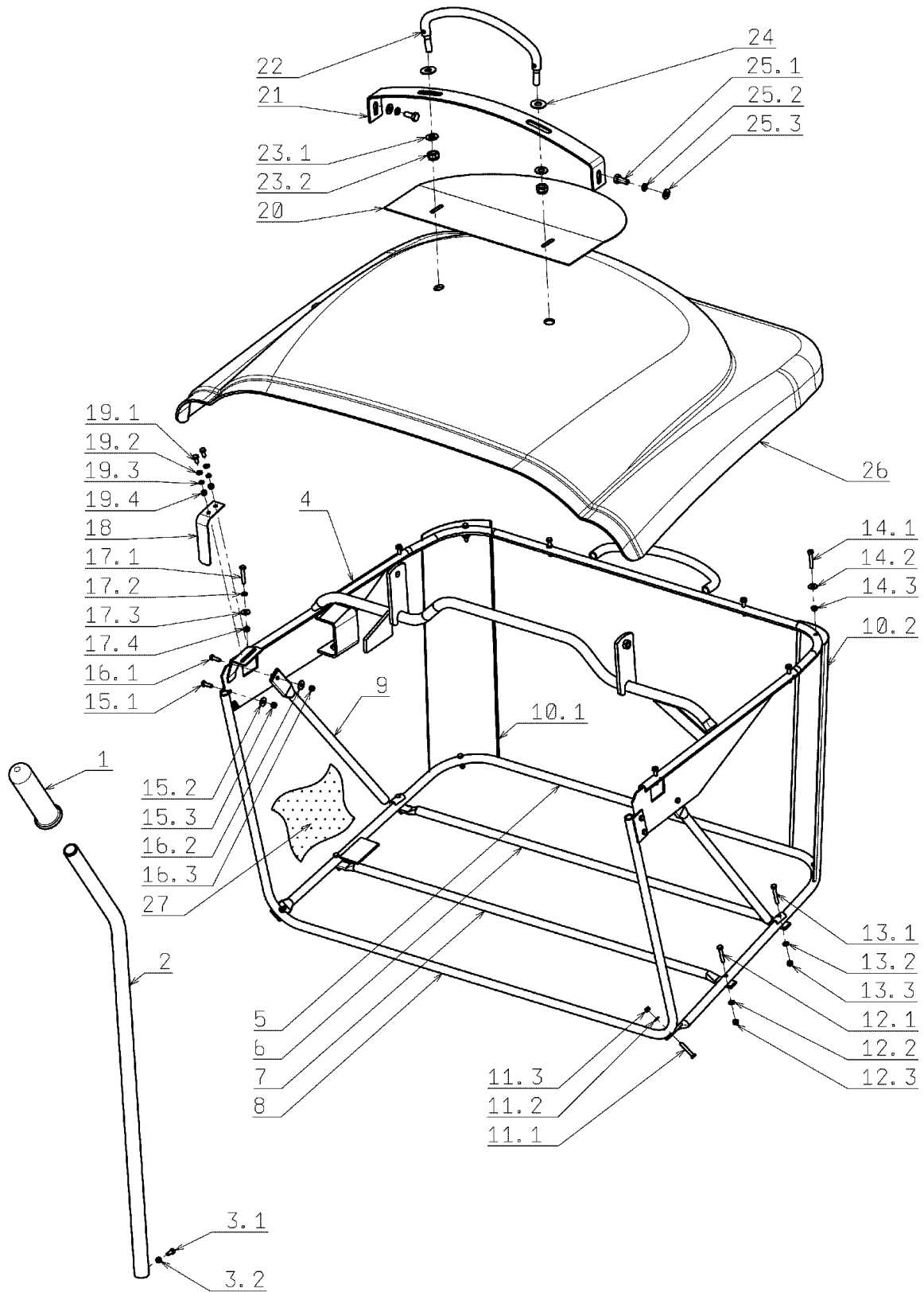

Illustration Grasfangkorb

Bild Nr.	St.- Zahl	Teile Nr.	Beschreibung
25.2	2	SG311214502	Scheibe
25.3	2	SG311210503	Scheibe
26	1	SG532150272	Deckel
27	1	SG532150256	Ersatzsack

Illustration Hinterachse

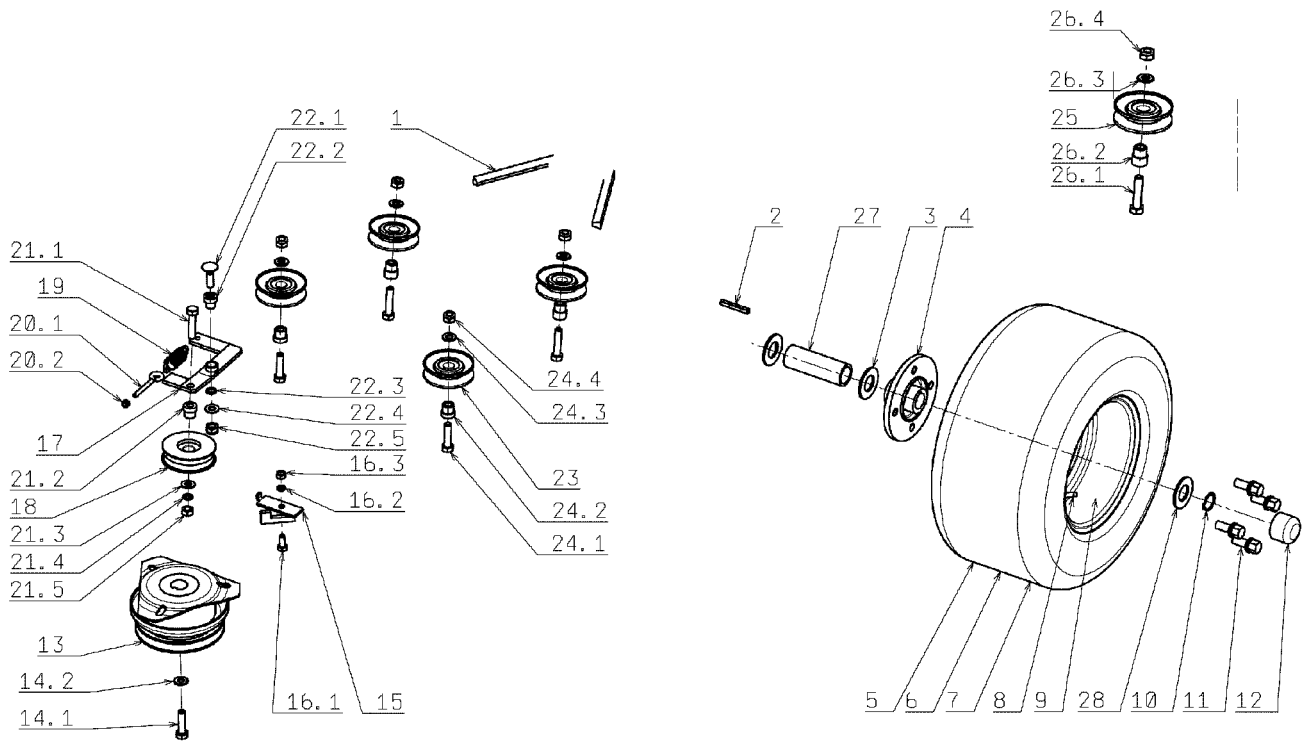

Illustration Hinterachse

Bild Nr.	St.- Zahl	Teile Nr.	Beschreibung
1	1	SG272731200	Riemen
2	2	SG532092312203	Feder
3	15	SG532092208083	Scheibe
4	2	SG532029214303	Deckel
5	2	SG532940087	Rad
6	2	SG000532132	Reifen
7	2	SG000532133	Reifenschlauch
8	2	SG000532135	Ventil
9	2	SG325111019	Schneidblatt
10	2	SG311733013	Ring
11	8	SG443900092	Schraube
12	2	SG532150208	Stopfen
13	1	SG947000532010	Kupplung
13	1	SG947339242006	Kupplung
14.1	1	SG309579509	Schraube
14.2	1	SG311219516	Scheibe
15	1	SG532936362163	Führung
16.1	2	SG309503518	Schraube
16.2	10	SG311214502	Scheibe
16.3	7	SG311150503	Mutter
17	1	SG532913322763	Halter
18	1	SG000532003	Scheibe
19	1	SG315231111	Feder
20.1	1	SG309578523	Schraube
20.2	1	SG311129513	Mutter
21.1	1	SG309019529	Schraube
21.2	1	SG532150544	Lager
21.3	1	SG311210504	Scheibe
21.4	1	SG311214503	Scheibe
21.5	1	SG311150506	Mutter
22.1	1	SG309203528	Schraube
22.2	1	SG532150545	Lager
22.3	1	SG311210504	Scheibe
22.4	1	SG311214503	Scheibe
22.5	1	SG311150506	Mutter
23	2	SG000532006	Scheibe
24.1	2	SG309501518	Schraube
24.2	2	SG532150524	Lager
24.3	2	SG311210504	Scheibe
24.4	2	SG311129502	Mutter
25	2	SG000532006	Scheibe
26.1	2	SG309201523	Schraube
26.2	2	SG532094214473	Buchse
26.3	2	SG311210504	Scheibe
26.4	2	SG311129502	Mutter
27	2	SG532195203523	Buchse

Illustration Hinterachse

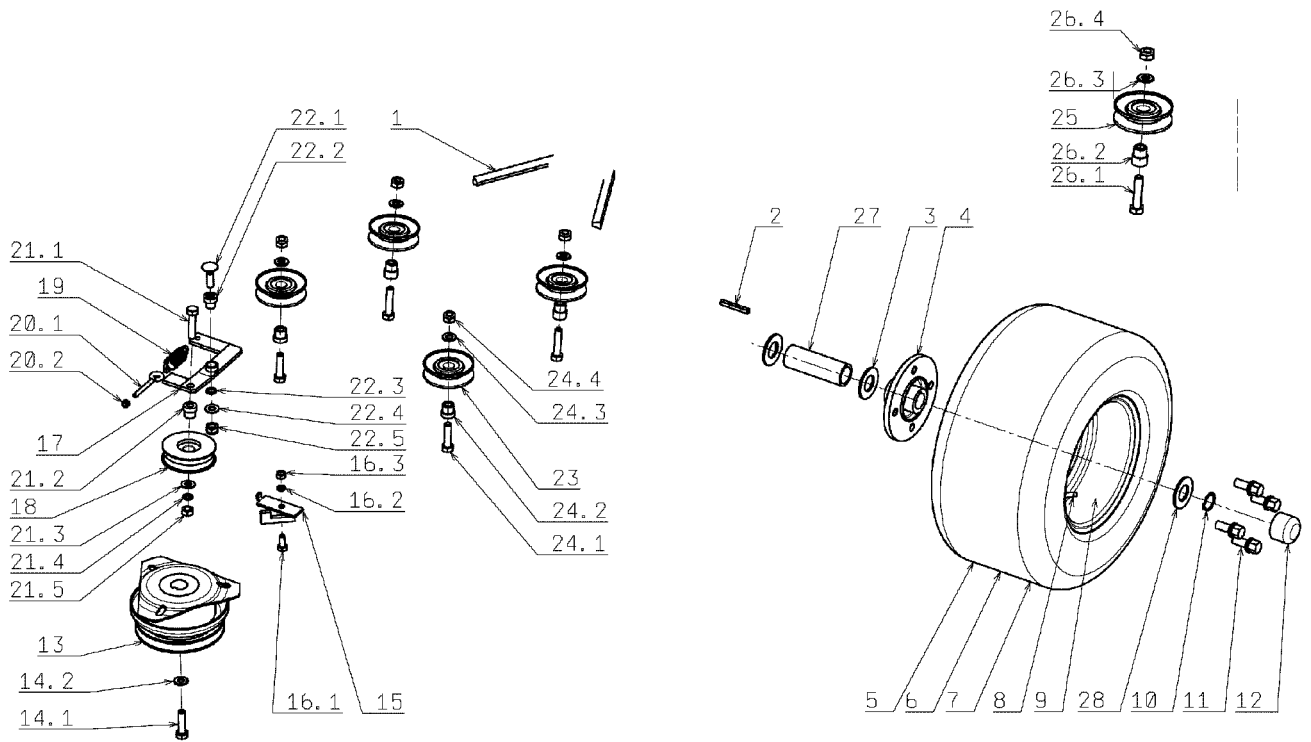

Illustration Hinterachse

Bild Nr.	St.- Zahl	Teile Nr.	Beschreibung
28	4	SG532092208053	Scheibe

Illustration Kapotte (1/2)

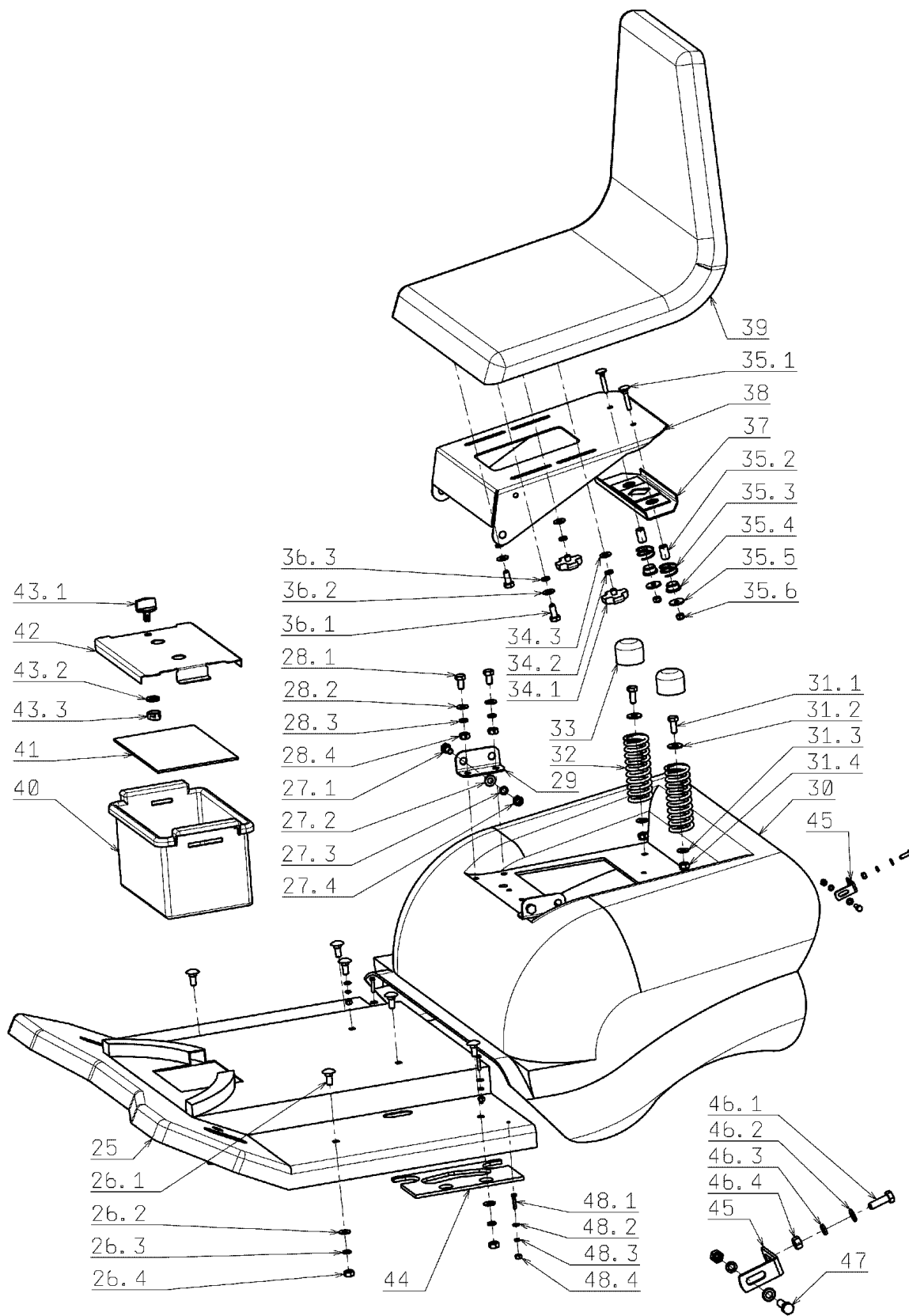

Illustration Kapotte (1/2)

Bild Nr.	St.- Zahl	Teile Nr.	Beschreibung
25	1	SG532150634	Rahmen
26.1	6	SG309019508	Schraube
26.2	6	SG311210503	Scheibe
26.3	6	SG311214502	Scheibe
26.4	6	SG311150503	Mutter
27.1	2	SG309599012	Schraube
27.2	2	SG311210503	Scheibe
27.3	2	SG311214502	Scheibe
27.4	2	SG311150503	Mutter
28.1	4	SG309503518	Schraube
28.2	4	SG311210503	Scheibe
28.3	4	SG311214502	Scheibe
28.4	4	SG311150503	Mutter
29	2	SG532113402403	Halter
30	1	SG532150637	Rahmen
31.1	2	SG309503512	Schraube
31.2	2	SG311212517	Scheibe
31.3	2	SG311210503	Scheibe
31.4	2	SG311129501	Mutter
32	2	SG315231124	Feder
33	2	SG532150208	Stopfen
34.1	2	SG532150213	Mutter
34.2	2	SG311213503	Scheibe
34.3	2	SG311219002	Scheibe
35.1	2	SG309019519	Schraube
35.2	2	SG532150442	Distanzstück
35.3	2	SG315231194	Feder
35.4	2	SG722643019	Feder
35.5	2	SG311212516	Schraube
35.6	2	SG311129513	Mutter
36.1	2	SG309503518	Schraube
36.2	2	SG311214502	Scheibe
36.3	2	SG311210503	Scheibe
37	1	SG532983362153	Bride
38	1	SG532018472433	Sitz
39	1	SG532150212	Sitz
40	1	SG532086422333	Werkzeugkasten
41	1	SG532199303413	Scheibe
42	1	SG532086422323	Deckel
43.1	1	SG532150109	Stift
43.2	1	SG532199303413	Scheibe
43.3	1	SG532150110	Buchse
45	2	SG532014342343	Schienenfuss
45	2	SG532014408153	Schienenfuss
46.1	2	SG309203539	Schraube
46.2	4	SG311212514	Scheibe

Illustration Kapotte (1/2)

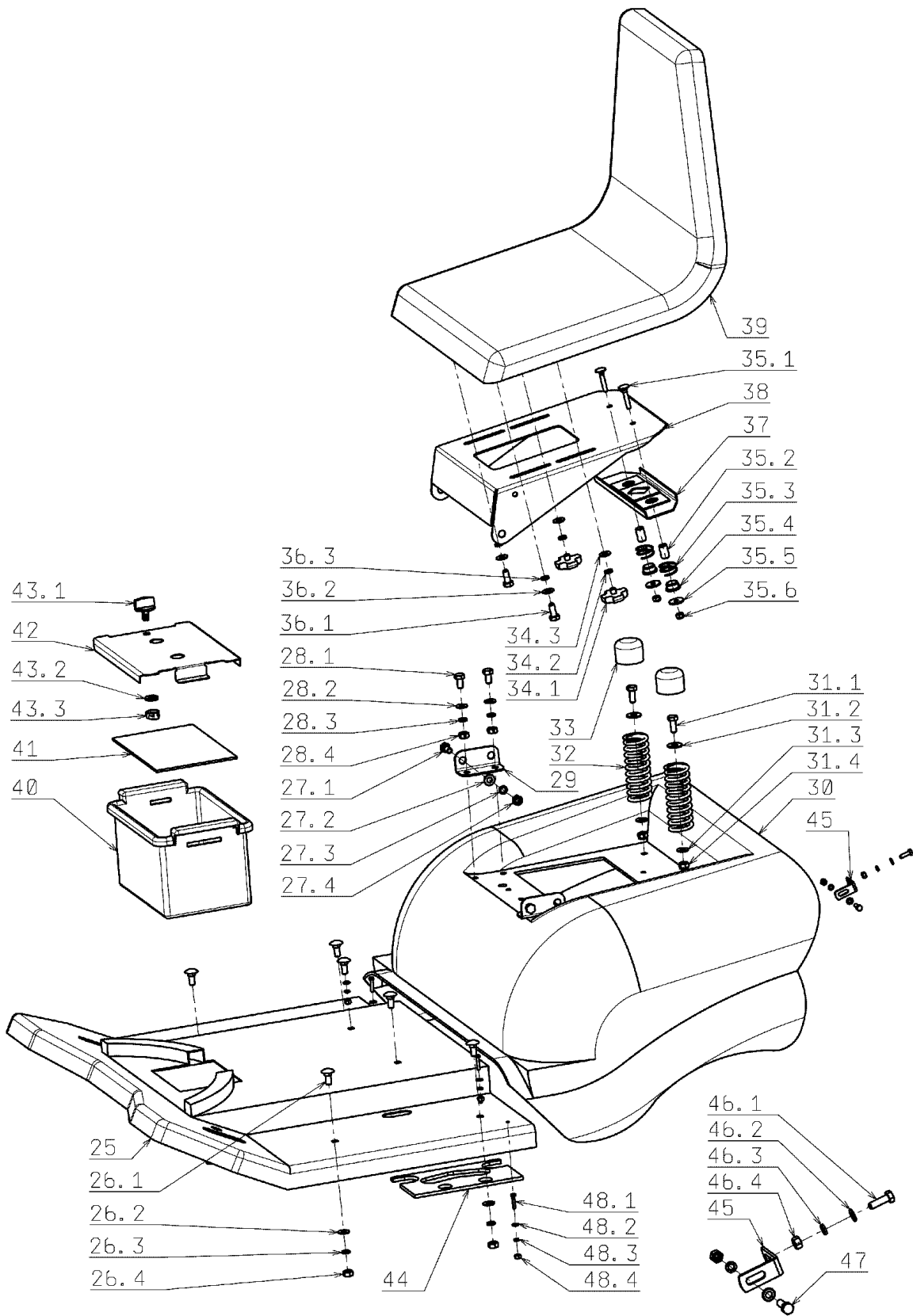

Illustration Kapotte (1/2)

Bild Nr.	St.- Zahl	Teile Nr.	Beschreibung
46.3	4	SG311214507	Scheibe
46.4	4	SG311120506	Mutter
47	2	SG309019514	Schraube
48.1	4	SG309019520	Schraube
48.2	4	SG311212511	Scheibe
48.3	4	SG311214507	Scheibe
48.4	4	SG311120506	Mutter

Illustration Kapotte (2/2)

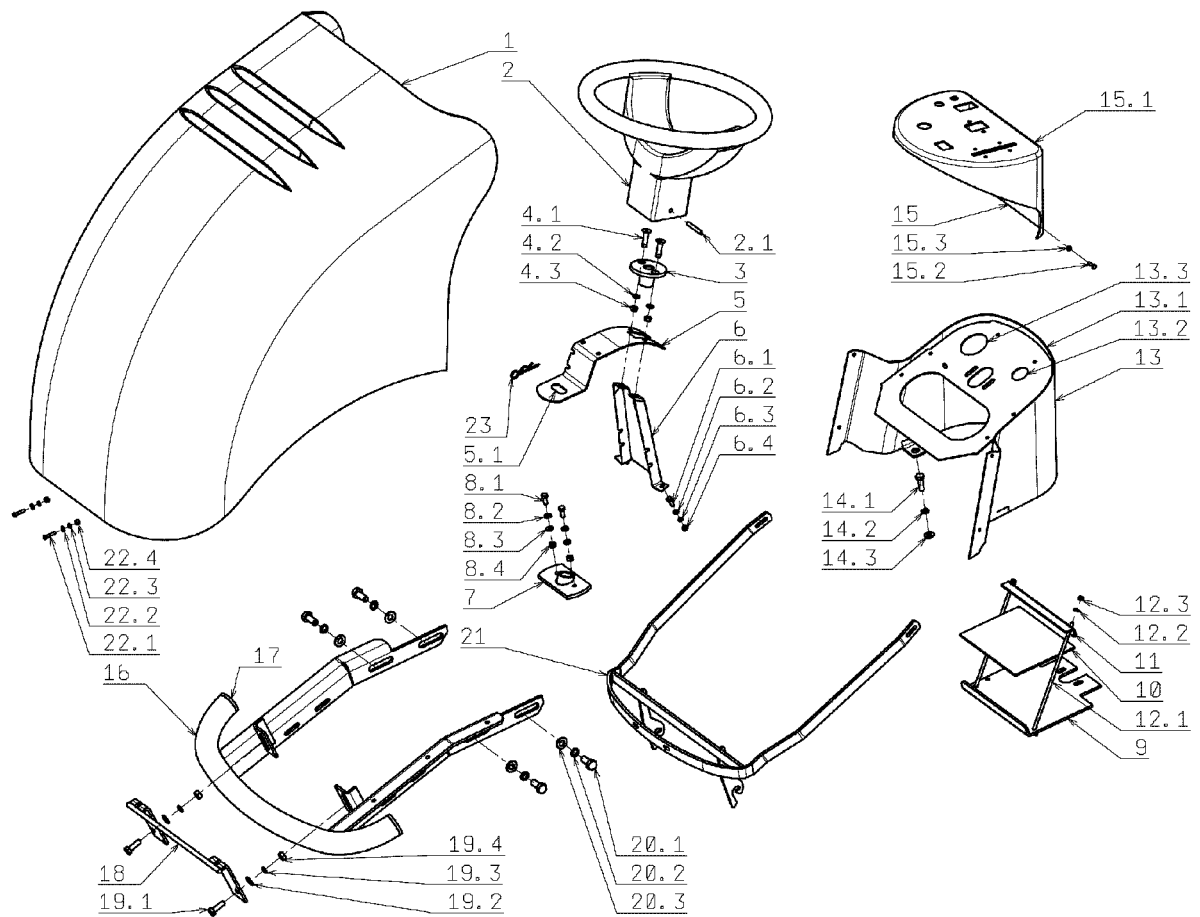

Illustration Kapotte (2/2)

Bild Nr.	St.- Zahl	Teile Nr.	Beschreibung
1	1	SG532918493063	Haube komplett
2	1	SG443821004	Lenkrad
2.1	1	SG315238031	Stift
3	1	SG532016522253	Deckel
4.1	2	SG309578503	Schraube
4.2	2	SG311210502	Scheibe
4.3	2	SG311129513	Mutter
5	1	SG532013424353	Halter
5.1	1	SG273121027	Durchführung
6	1	SG532013424373	Bride
6.1	6	SG309203539	Schraube
6.2	4	SG311212514	Scheibe
6.3	2	SG311210501	Scheibe
6.4	6	SG311129515	Mutter
7	1	SG532938703463	Lager
8.1	2	SG309203501	Schraube
8.2	2	SG311210502	Scheibe
8.3	2	SG311212516	Schraube
8.4	2	SG311129513	Mutter
9	1	SG532113413923	Halter
10	1	SG532096303073	Scheibe
11	1	SG532113403243	Halter
12.1	2	SG532150464	Kabel
12.2	2	SG311212514	Scheibe
12.3	2	SG311129515	Mutter
13	1	SG532980472093	Welle
13.1	1	SG532096342153	Dichtung
13.2	1	SG273121036	Buchse
13.3	1	SG532096342053	Kabel
14.1	4	SG309503512	Schraube
14.2	4	SG311214502	Scheibe
14.3	4	SG311212517	Scheibe
15	1	SG532150684	Blechtafel
15.1	4	SG532150238	Deckel
15.2	2	SG309251511	Schraube
15.3	2	SG311129514	Mutter
16	1	SG532918962473	Stossstangen
17	2	SG321841068	Rohr
18	1	SG532913402953	Halter
19.1	2	SG309503518	Schraube
19.2	2	SG311210503	Scheibe
19.3	2	SG311214502	Scheibe
19.4	2	SG311150503	Mutter
20.1	4	SG309503502	Schraube
20.2	4	SG311210504	Scheibe
20.3	4	SG311214503	Scheibe

Illustration Kapotte (2/2)

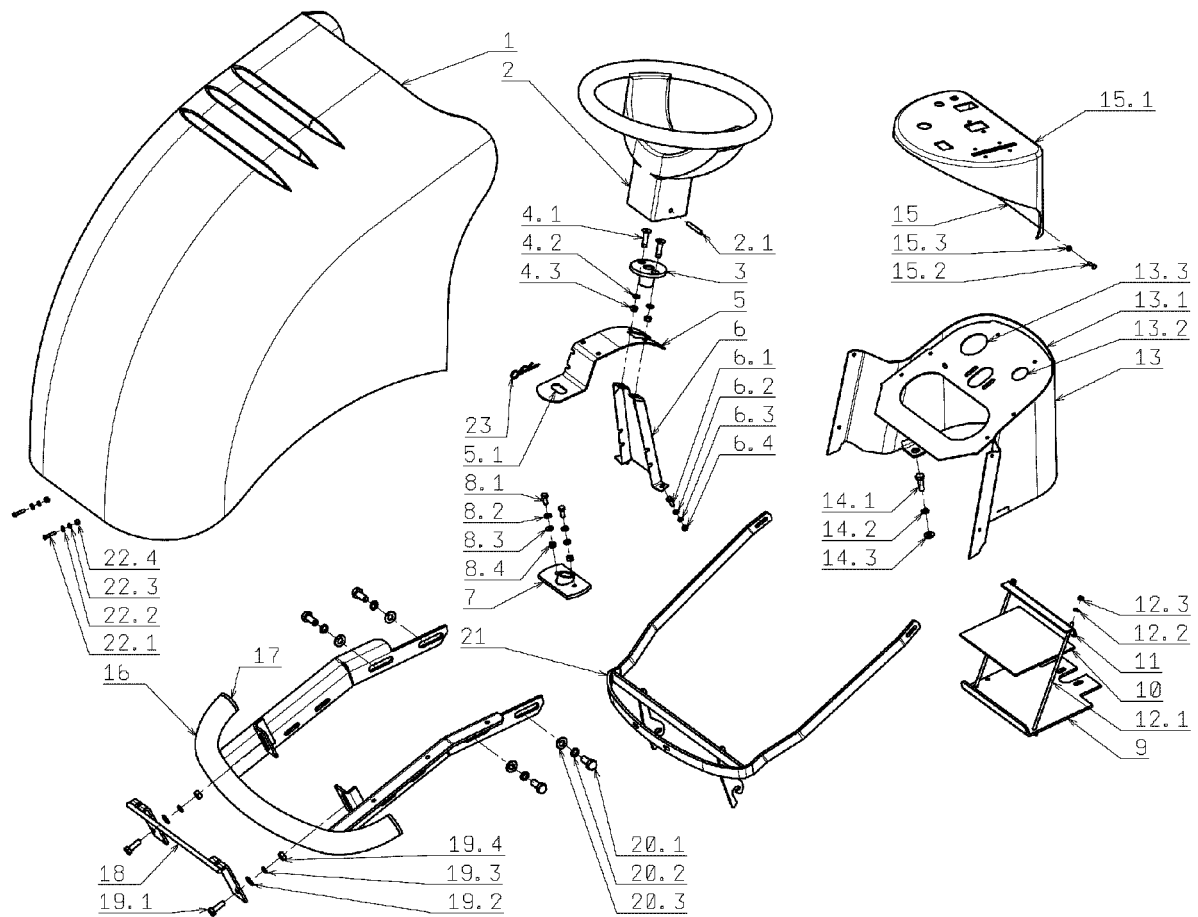

Illustration Kapotte (2/2)

Bild Nr.	St.- Zahl	Teile Nr.	Beschreibung
21	1	SG532918462253	Haubenthalter
22.1	4	SG309019521	Schraube
22.3	4	SG311214507	Scheibe
22.4	4	SG311120506	Mutter
23	1	SG315238005	Stift

Illustration Lenkgetriebe

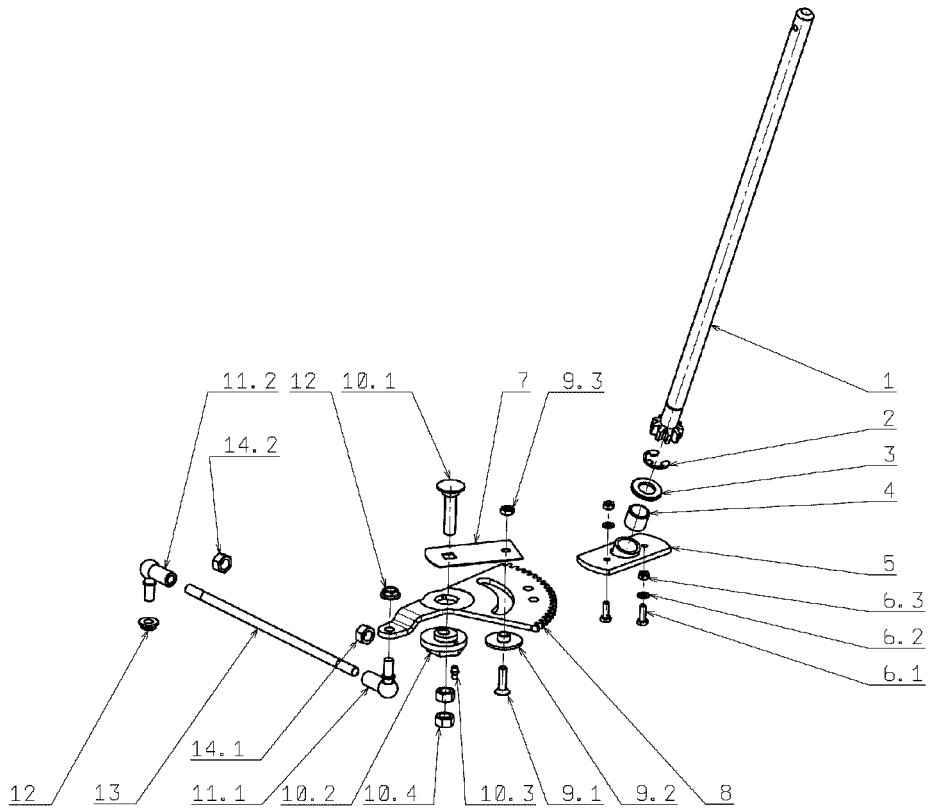

Illustration Lenkgetriebe

Bild Nr.	St.- Zahl	Teile Nr.	Beschreibung
1	1	SG532930252153	Ritzel
2	1	SG311732008	Ring
3	1	SG311210514	Scheibe
4	1	SG323721002	Lager
5	1	SG532938703433	Halter
6.1	2	SG309503548	Schraube
6.2	2	SG311212516	Schraube
6.3	2	SG311129513	Mutter
7	1	SG532113322803	Platte
8	1	SG532033322083	Zahnrad
9.1	1	SG309578506	Schraube
9.2	1	SG532150538	Distanzstück
9.3	1	SG311120520	Mutter
10.1	1	SG309019522	Schraube
10.2	1	SG532080272033	Exzenter
10.3	1	SG425111004	Fettnippel
10.4	2	SG311150505	Mutter
11.1	1	SG442073019	Dichtung
11.2	1	SG442073020	Dichtung
12	2	SG311129521	Mutter
13	1	SG532980125	Distanzstück
14.1	1	SG311120539	Mutter
14.2	1	SG311150505	Mutter

Illustration Mäheraushebung-schaltung

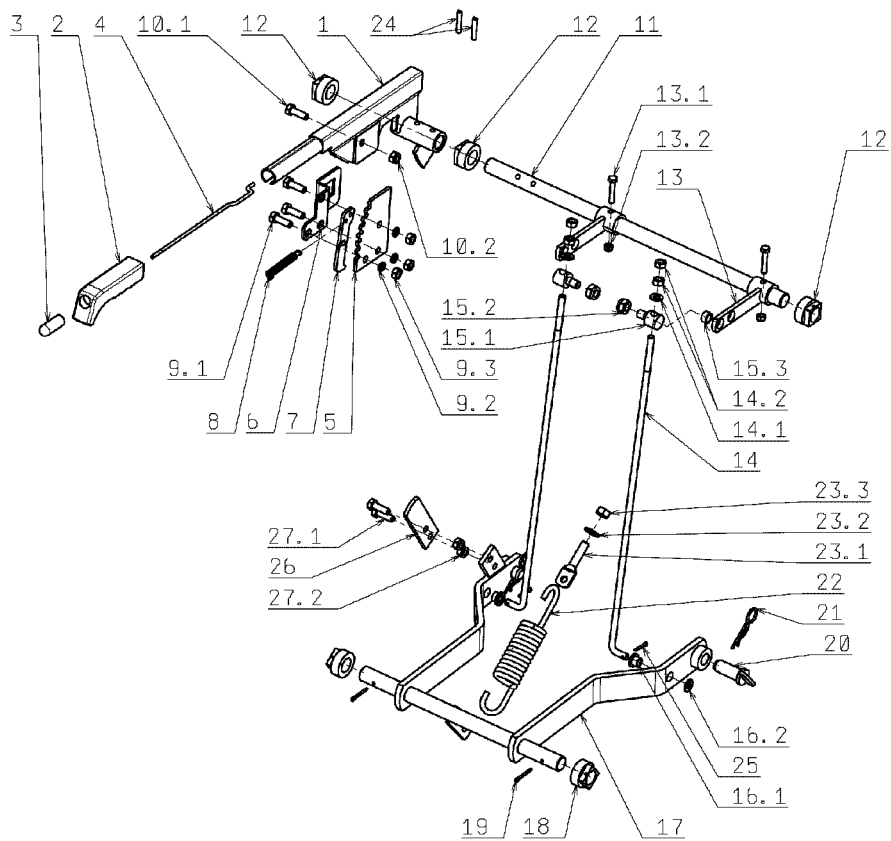

Illustration Mäheraushebung-schaltung

Bild Nr.	St.- Zahl	Teile Nr.	Beschreibung
1	1	SG532980522163	Hebel
2	1	SG532150049	Handgriff
3	1	SG722643016	Toranschluss
4	1	SG315238034	Stange
5	1	SG532037322183	Zahnrad
6	1	SG532113414183	Halter
7	1	SG532150641	Platte
8	1	SG315231158	Feder
9.1	3	SG309503512	Schraube
9.2	3	SG311214502	Scheibe
9.3	3	SG311150503	Mutter
10.1	1	SG309503512	Schraube
10.2	1	SG311129501	Mutter
11	1	SG532038102853	Welle
12	3	SG722643022	Buchse
13	2	SG532980462853	Arm
13.1	2	SG309501568	Schraube
13.2	2	SG311129513	Mutter
14	2	SG532080402683	Hebel
14.1	2	SG311210503	Scheibe
14.2	4	SG311150503	Mutter
15.1	2	SG532150507	Schraube
15.2	2	SG311129502	Mutter
15.3	2	SG532195203273	Distanzstück
16.1	2	SG532150537	Ring
16.2	2	SG311210503	Scheibe
17	1	SG532980508103	Hebel
18	2	SG722643022	Buchse
19	2	SG311338517	Stift
20	2	SG532993462153	Stift
21	2	SG315238035	Stift
22	1	SG315231165	Feder
23.1	1	SG309599018	Schraube
23.2	1	SG311214503	Scheibe
23.3	1	SG311150506	Mutter
24	2	SG315238041	Stift
26	1	SG532114327223	Kupplungsblock
27.1	2	SG309578522	Schraube
27.2	2	SG311129501	Mutter

Illustration Motor

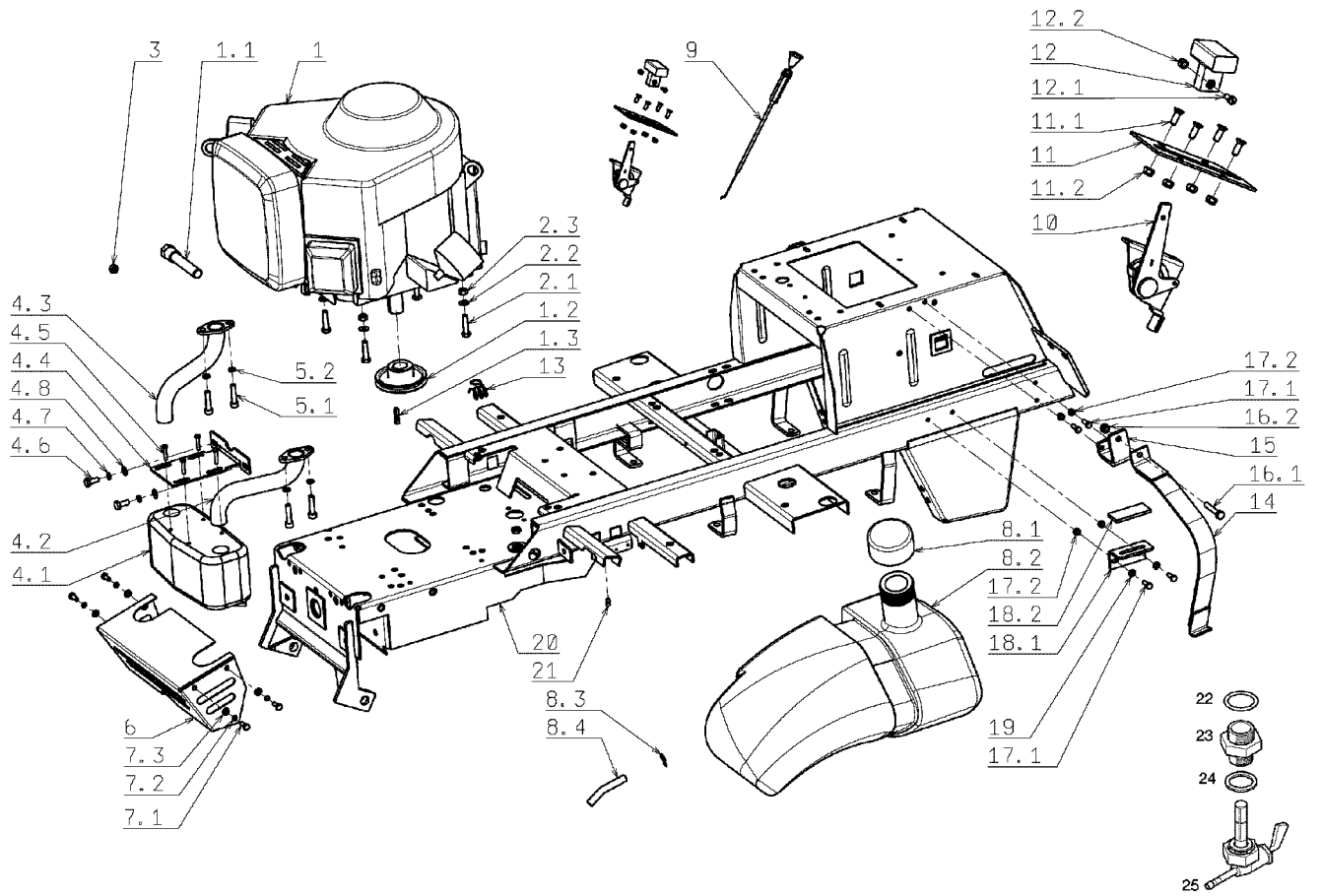

Illustration Motor

Bild Nr.	St.- Zahl	Teile Nr.	Beschreibung
1.1	1	SG532927262043	Verlaengerung
1.2	1	SG000532012	Scheibe
1.3	1	SG532092312133	Schlüssel
2.1	4	SG309503543	Schraube
2.2	4	SG311214502	Scheibe
2.3	4	SG311150503	Mutter
3	1	SG311122501	Mutter
4.1	1	SG443900129	Rohr
4.2	1	SG532927442193	Rohr
4.3	1	SG532927442183	Rohr
4.4	1	SG532113404483	Halter
4.5	4	SG309315009	Schraube
4.6	2	SG309503518	Schraube
4.7	2	SG311212517	Scheibe
4.8	2	SG311210503	Scheibe
5.1	4	SG309579501	Mutter
5.2	6	SG311214502	Scheibe
6	1	SG532985423333	Deckel
7.1	4	SG309503508	Schraube
7.2	4	SG311214501	Scheibe
7.3	4	SG311210502	Scheibe
8.1	1	SG321841017	Stopfen
8.2	1	SGN232130013	Tank
8.3	2	SG000532058	Klammer
8.4	1	SG532199202463	Schlauch
9	1	SG443612011	Hebel
10	1	SG443900085	Hebel
11	1	SG532080302873	Verstaerkung
11.1	4	SG309251514	Schraube
11.2	4	SG311129515	Mutter
12	1	SG443900093	Hebel
12.1	1	SG309231505	Schraube
12.2	1	SG311129514	Mutter
13	1	SG532092422423	Feder
14	1	SG532913422643	Halter
15	1	SG532013425133	Halter
16.1	1	SG309543514	Schraube
16.2	1	SG311129501	Mutter
17.1	2	SG309503548	Schraube
17.2	4	SG311129513	Mutter
18.1	1	SG532113404223	Halter
18.2	1	SG273445012	Dichtung
19	2	SG311210503	Scheibe
20	1	SG532912962633	Rahmen
21	2	SG425111004	Fettnippel
22	1	SGN273111059	Dichtung

Illustration Motor

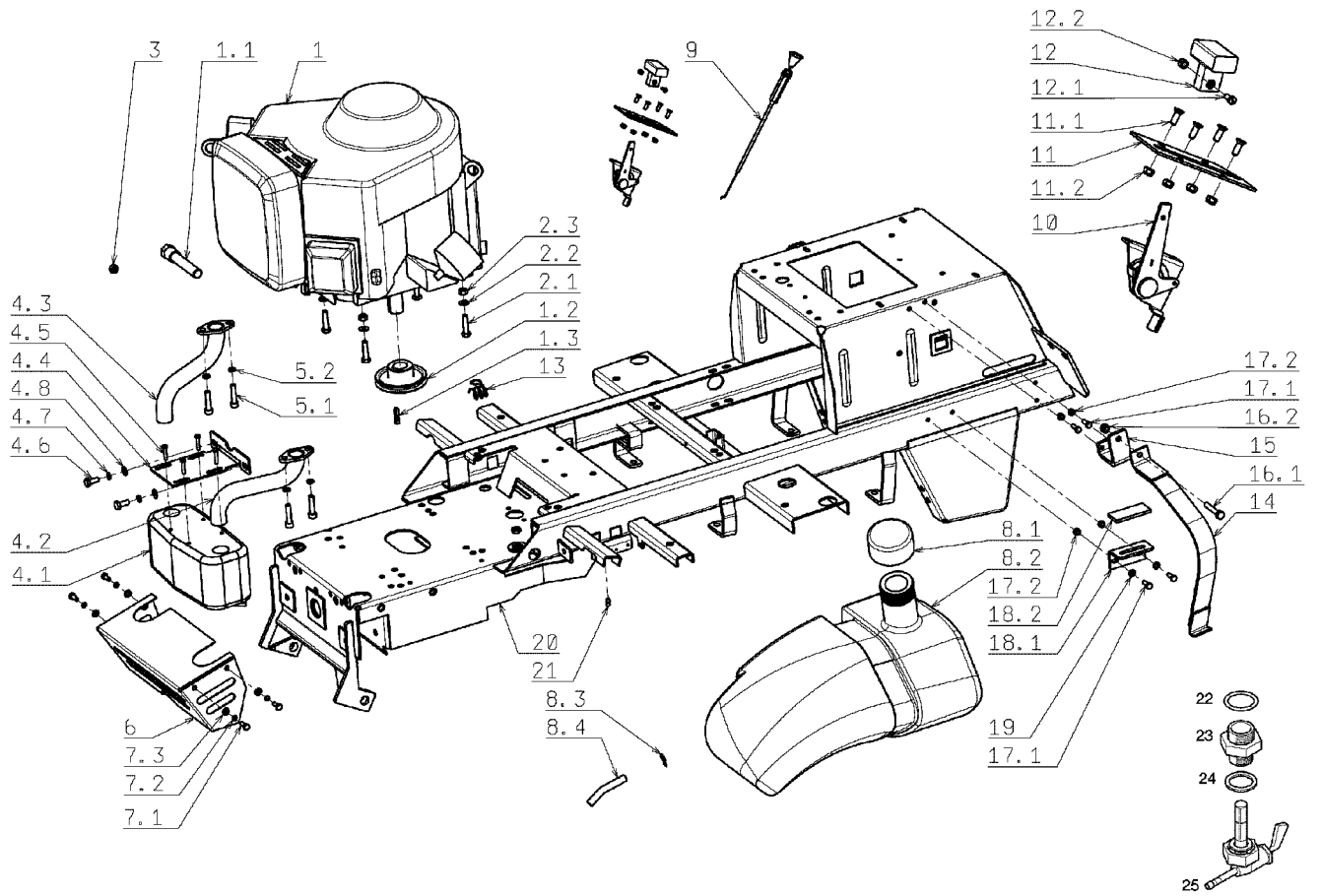

Illustration Motor

Bild Nr.	St.- Zahl	Teile Nr.	Beschreibung
23	1	SGN532150839	Nippel
24	1	SGN22923015	Dichtung
25	1	SGN532150840	Hahn

Illustration Schneidwerkzeug (1/2)

Bild Nr.	St.- Zahl	Teile Nr.	Beschreibung
1	1	SG532950472083	Deck
2.1	2	SG532038523833	Deckel
2.2	2	SG532098203373	Dichtung
3	4	SG324162099	Lager
4.1	6	SG309503543	Schraube
4.2	6	SG311210503	Scheibe
4.3	6	SG311129501	Mutter
5	1	SG532038128023	Welle
6.1	1	SG311726009	Feder
6.2	2	SG311726014	Feder
7	1	SG532038128033	Welle
8	1	SG311726019	Feder
9	2	SG311733014	Ring
10	2	SG532098212403	Anpassungsglied
11	4	SG532980077	Buchse
12	1	SG532050422543	Blatt
13	1	SG532050422533	Blatt
14.1	1	SG309599017	Schraube
14.2	2	SG532150519	Scheibe
14.3	2	SG311219503	Scheibe
15	1	SG309599008	Schraube
16.1	2	SG532150533	Scheibe
16.2	2	SG273111056	Ring
16.3	2	SG311120511	Mutter
17	4	SG532940117	Rad
18.1	4	SG309501567	Schraube
18.2	4	SG311129501	Mutter
19	1	SG532080503503	Einstellen
20	1	SG532193102893	Stift
21	2	SG315238035	Stift
22	2	SG311613002	Buchse
23	4	SG315238003	Stift

Illustration Schneidwerkzeug (2/2)

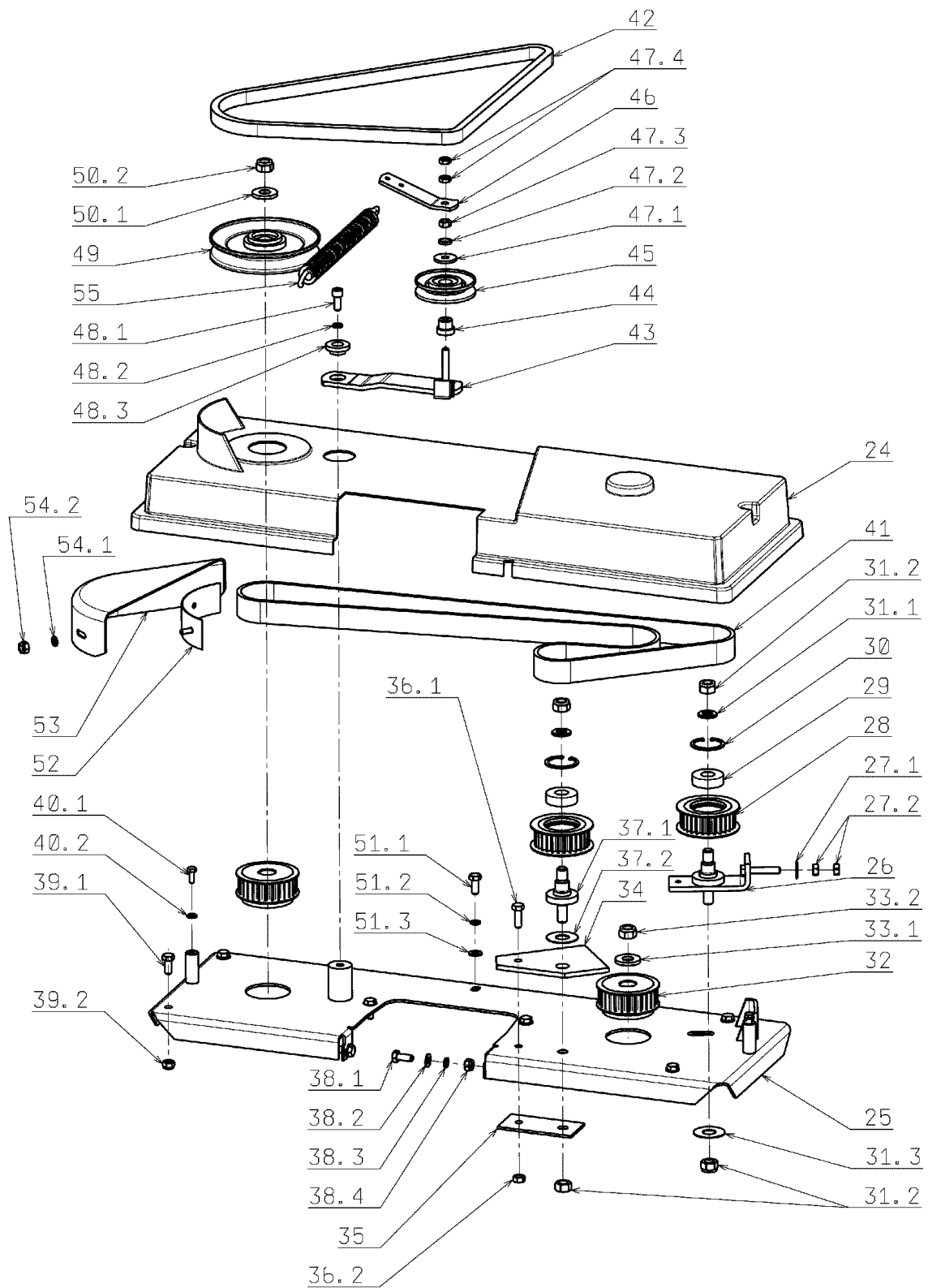

Illustration Schneidwerkzeug (2/2)

Bild Nr.	St.- Zahl	Teile Nr.	Beschreibung
24	1	SG532150210	Deckel
25	1	SG532985423313	Platte
26	1	SG532914412313	Mutter
27.1	1	SG311212517	Scheibe
27.2	2	SG311150503	Mutter
28	1	SG532933712743	Scheibe
29	2	SG324162098	Lager
30	2	SG311733079	Ring
31.1	2	SG311210505	Scheibe
31.2	4	SG311129505	Mutter
31.3	1	SG532092207533	Scheibe
32	2	SG532933712773	Scheibe
33.1	1	SG532150645	Scheibe
33.2	1	SG311129505	Mutter
34	1	SG532096303973	Halter
35	1	SG532092303963	Halter
36.1	1	SG309503512	Schraube
36.2	1	SG311129501	Mutter
37.1	1	SG532993122683	Stift
37.2	1	SG532092207703	Scheibe
38.1	2	SG309019501	Schraube
38.2	2	SG311210505	Scheibe
38.3	2	SG311210503	Scheibe
38.4	2	SG311129501	Mutter
39.1	6	SG309503518	Schraube
39.2	6	SG311129501	Mutter
40.1	2	SG309503548	Schraube
40.2	6	SG311212516	Schraube
41	1	SG272211006	Riemen
42	1	SG272731193	Riemen 17x1350
42	1	SG947272731192	Riemen 17x1400
43	1	SG532913422403	Hebel
44	1	SG532150517	Buchse
45	1	SG000532002	Scheibe
46	1	SG532113402353	Hebel
47.1	1	SG311212508	Scheibe
47.2	1	SG311214502	Scheibe
47.3	1	SG311150503	Mutter
47.4	2	SG311120520	Mutter
48.1	1	SG309543521	Schraube
48.2	1	SG311214502	Scheibe
48.3	1	SG532150520	Scheibe
49	1	SG532150165	Riemenscheibe
50.1	1	SG532150645	Scheibe
50.2	1	SG311129505	Mutter
51.1	1	SG309503518	Schraube

Illustration Schneidwerkzeug (2/2)

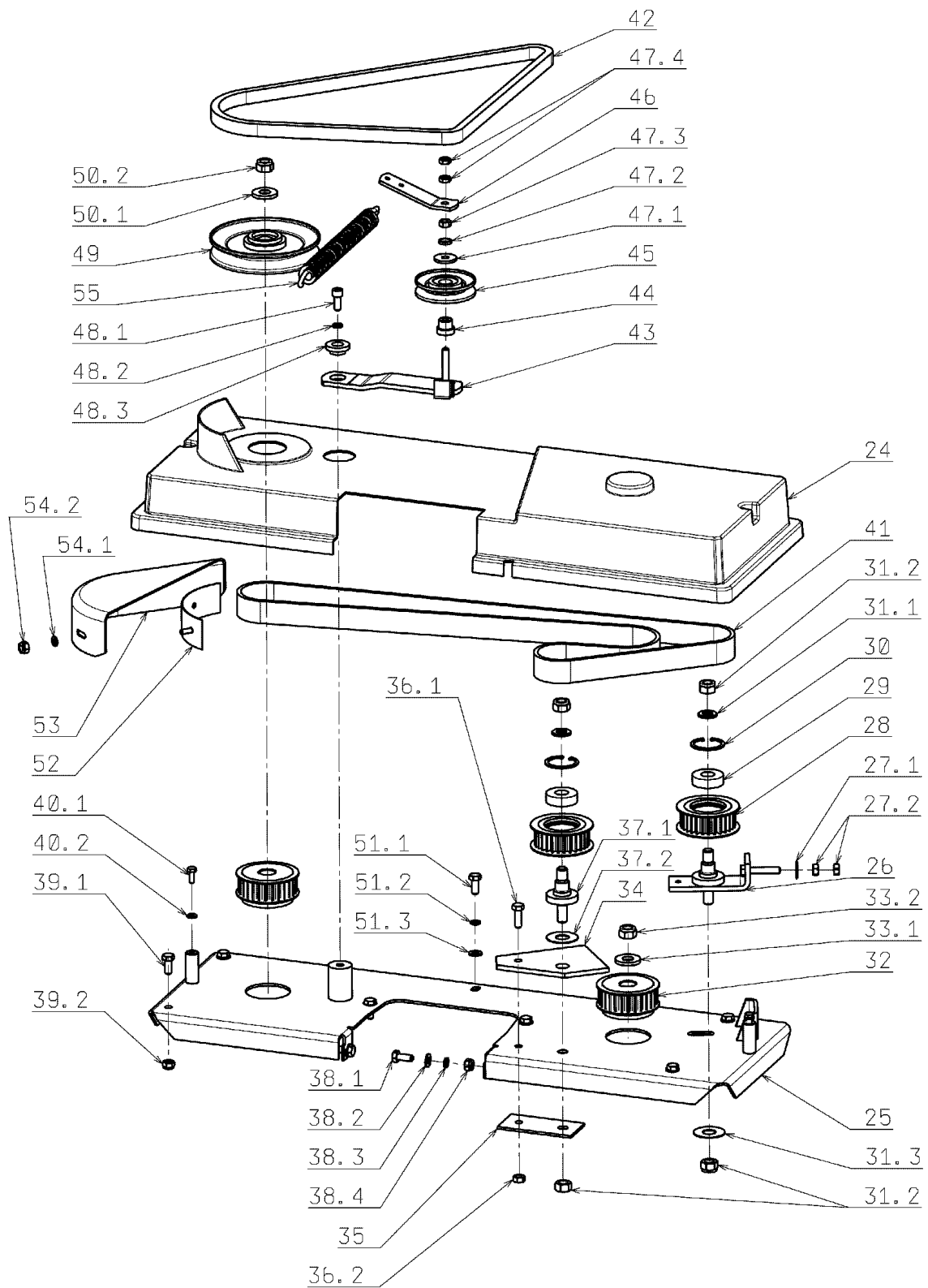

Illustration Schneidwerkzeug (2/2)

Bild Nr.	St.- Zahl	Teile Nr.	Beschreibung
51.2	1	SG311214502	Scheibe
51.3	1	SG311210503	Scheibe
52	1	SG532985402733	Dichtung
53	1	SG532150559	Riemen
54.1	2	SG311212516	Schraube
54.2	2	SG311129513	Mutter
55	1	SG315231193	Feder

Illustration Vorderachse

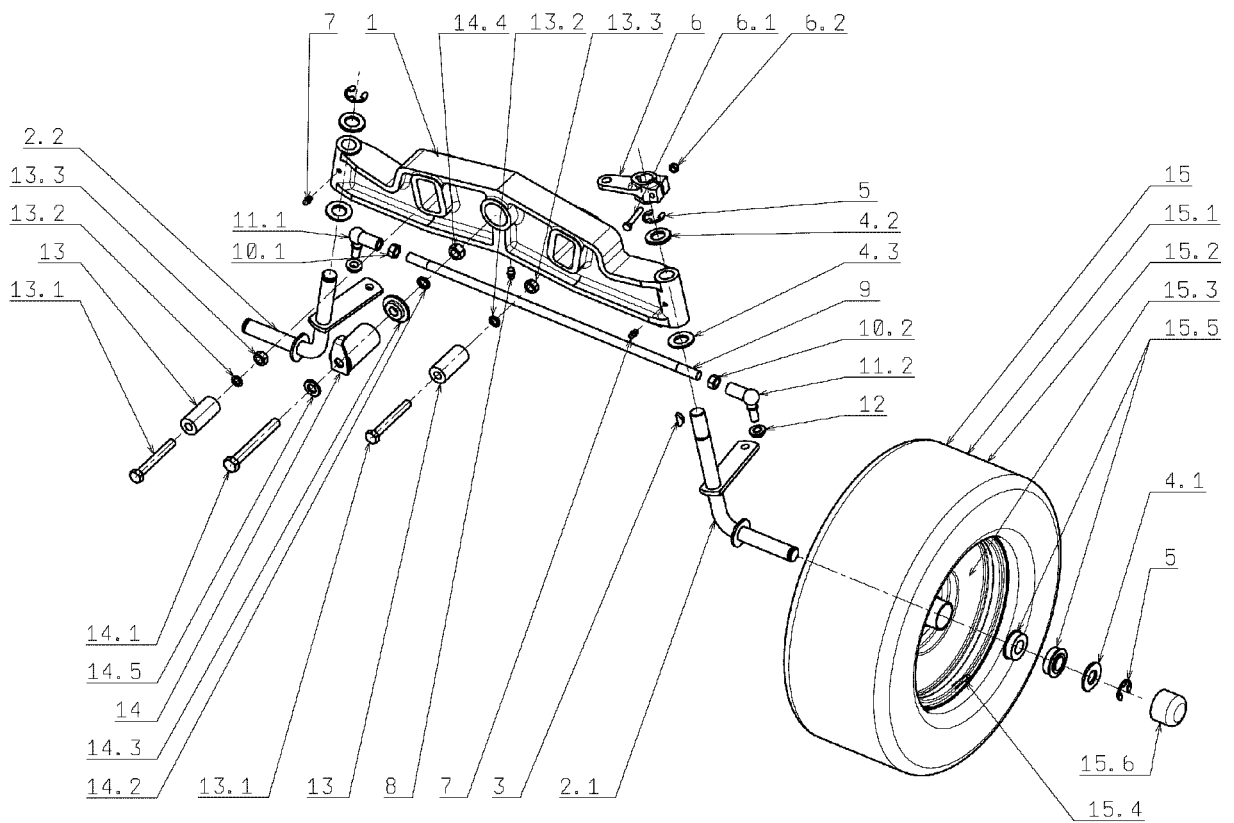

Illustration Vorderachse

Bild Nr.	St.- Zahl	Teile Nr.	Beschreibung
1	1	SG532016542063	Vorn achse
2.1	1	SG532916432143	Stift
2.2	1	SG532916432153	Stift
3	1	SG311728003	Feder
4.1	2	SG532092207393	Scheibe
4.2	4	SG311210514	Scheibe
4.3	4	SG532092208153	Scheibe
5	2	SG311732008	Ring
6	1	SG532080503603	Hebel
6.1	1	SG309203524	Schraube
6.2	1	SG311129513	Mutter
7	2	SG425111004	Fettnippel
8	1	SG425111016	Fettnippel
9	1	SG532980126	Stange
10.1	1	SG311150505	Mutter
10.2	1	SG311120539	Mutter
11.1	1	SG442073020	Dichtung
11.2	1	SG442073019	Dichtung
12	2	SG311129521	Mutter
13	2	SG532150543	Distanzstuck
13.1	2	SG309501527	Schraube
13.2	2	SG311214503	Scheibe
13.3	2	SG311150506	Mutter
14	1	SG532993164373	Stift
14.1	1	SG309501534	Schraube
14.2	1	SG311214504	Scheibe
14.3	1	SG532150518	Scheibe
14.4	1	SG311150505	Mutter
14.5	1	SG311210505	Scheibe
15	2	SG532940111	Rad
15.1	2	SG000532123	Reifen
15.2	2	SG000532125	Reifenschlauch
15.3	2	SG000532124	Schneidblatt
15.4	2	SG000532135	Ventil
15.5	4	SG324196015	Lager
15.6	2	SG532150208	Stopfen